



12FGHL604

12Volt 200Ah

Specifications

Nominal Voltage(V) **12V**

Nominal Capacity

10 hour rate	(20A	to	10.80V)	200Ah
5 hour rate	(34A	to	10.20V)	170Ah
1 hour rate	(120A	to	9.60V)	120Ah

Weight **Approx. 61.5kg(135Lbs.)**

Internal Resistance (at 1KHz) **Approx. 3 mΩ**

Maximum Discharge Current for 5 seconds: **1600A**

Charging Methods at 25 (77)

Cycle use:	
Charging Voltage	14.4 to 15.0V
Coefficient -5.0mV/	/cell
Maximum Charging Current :	60A
Standby use:	
Float Charging Voltage	13.5 to 13.8V
Coefficient -3.0mV/	/cell

Operating Temperature Range

Charge	-15 (5)	to	40 (104)
Discharge	-15 (5)	to	50 (122)
Storage	-15 (5)	to	40 (104)

Design Life **12 years**

Charge Retention (shelf life) at 20 (68)

1 month	98%
3 month	94%
6 month	85%

Case Material **ABS UL94 HB**

Terminal **F18**

Description of torque value of hard ware for the terminals:
 Recommended torque value **M8: 7 N-m (71kgf-cm)**
 Maximum allowable torque value **M8: 9 N-m (92kgf-cm)**



Dimensions mm(inch)

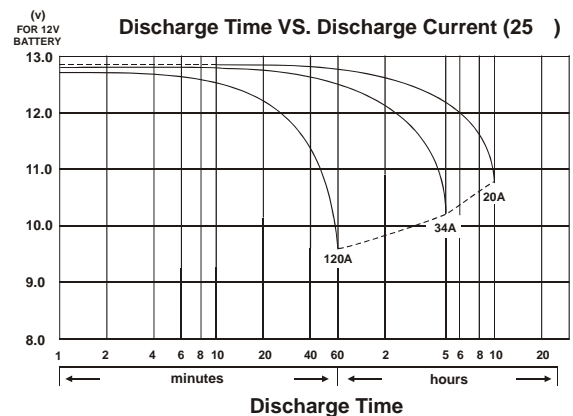
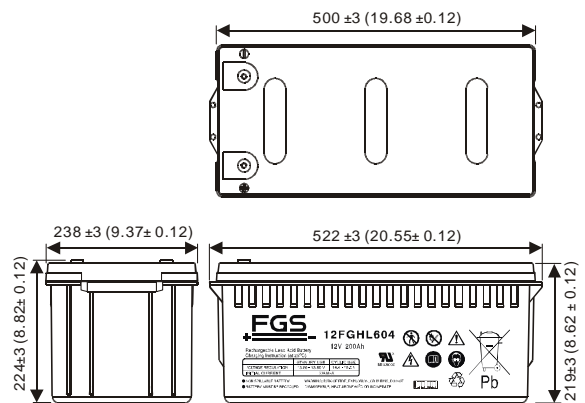
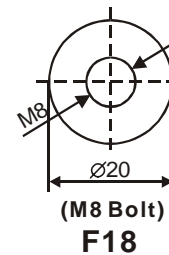

Effect of Temperature on Capacity 25°C(77°F)

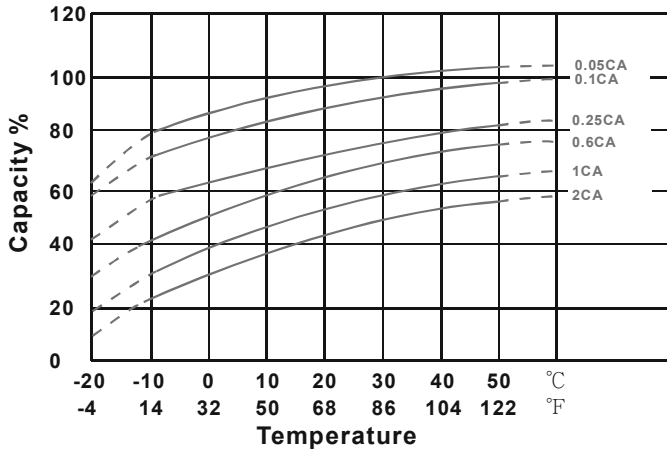

Capacity Retention Characteristic

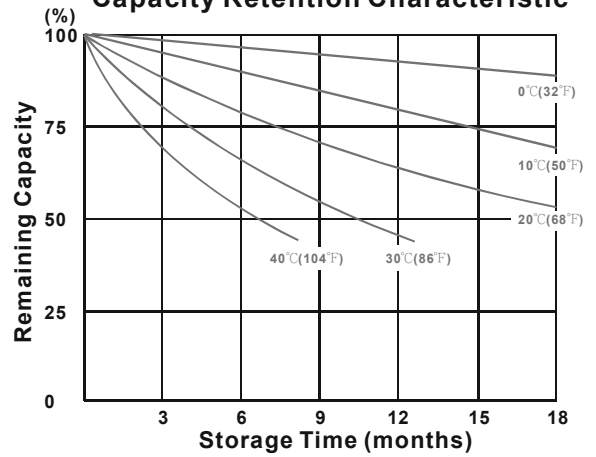

Trickle (or float) Service Life

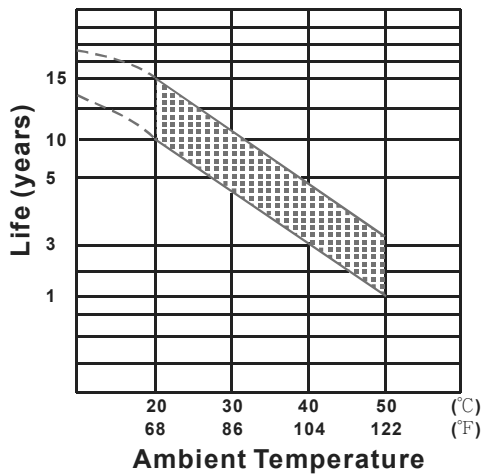

Cycle Service Life

